



US006354403B1

(12) **United States Patent**
Truckner et al.

(10) **Patent No.:** **US 6,354,403 B1**
(45) **Date of Patent:** **Mar. 12, 2002**

(54) **ADJUSTABLE STAIR STRINGER AND RAILING**

4,124,957 A * 11/1978 Poulain 52/183
4,959,935 A * 10/1990 Stob 52/183
5,636,483 A * 6/1997 Wille 182/188

(76) Inventors: **Richard Truckner; Paul Truckner,**
both of 3862 Depot Rd., Hayward, CA
(US) 94545

* cited by examiner

Primary Examiner—Alvin Chin-Shue

(74) *Attorney, Agent, or Firm*—George W. Wasson

(*) Notice: Subject to any disclaimer, the term of this patent is extended or adjusted under 35 U.S.C. 154(b) by 0 days.

(57) **ABSTRACT**

An adjustable stair stringer and railing construction assembly is disclosed. The assembly is adapted to use a pair of parallel stringer arms for each side of the stair, a riser/tread support bracket for each stair, and alignment and spacing elements for spacing the support brackets along the stringers. The brackets include formations for spacing the stringers with respect to each other and for spacing adjacent brackets along the stringers. The brackets are initially pivotally attached to each of the stringers so as to be rotatably movable about their pivotal attachment as the stringers are moved axially. Axial movement of the stringers with respect to each other establishes the angle of rise of the stair. Treads and risers are attached to the brackets to form the stairs and railings are attachable to the stringer and bracket assembly to complete the construction.

(21) Appl. No.: **09/315,809**

(22) Filed: **May 21, 1999**

Related U.S. Application Data

(60) Provisional application No. 60/085,151, filed on May 21, 1998.

(51) **Int. Cl.**⁷ **E04F 11/00**

(52) **U.S. Cl.** **182/228.1; 52/183; 182/1**

(58) **Field of Search** **182/1, 228.1; 52/183**

(56) **References Cited**

U.S. PATENT DOCUMENTS

1,189,514 A * 7/1916 Wallace

5 Claims, 22 Drawing Sheets

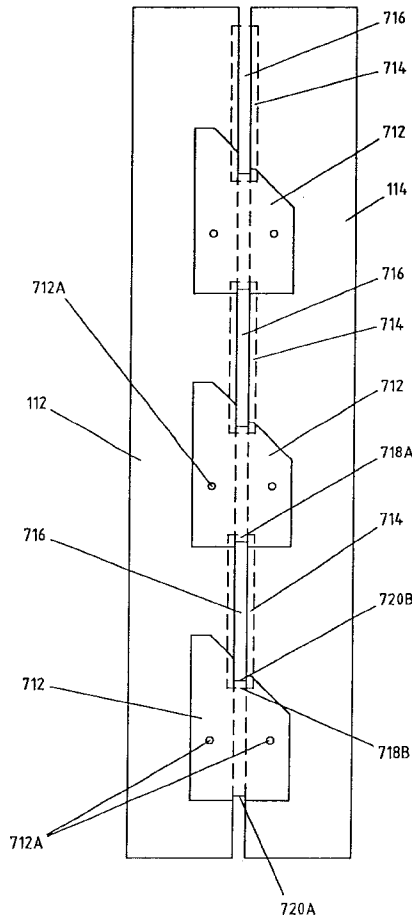

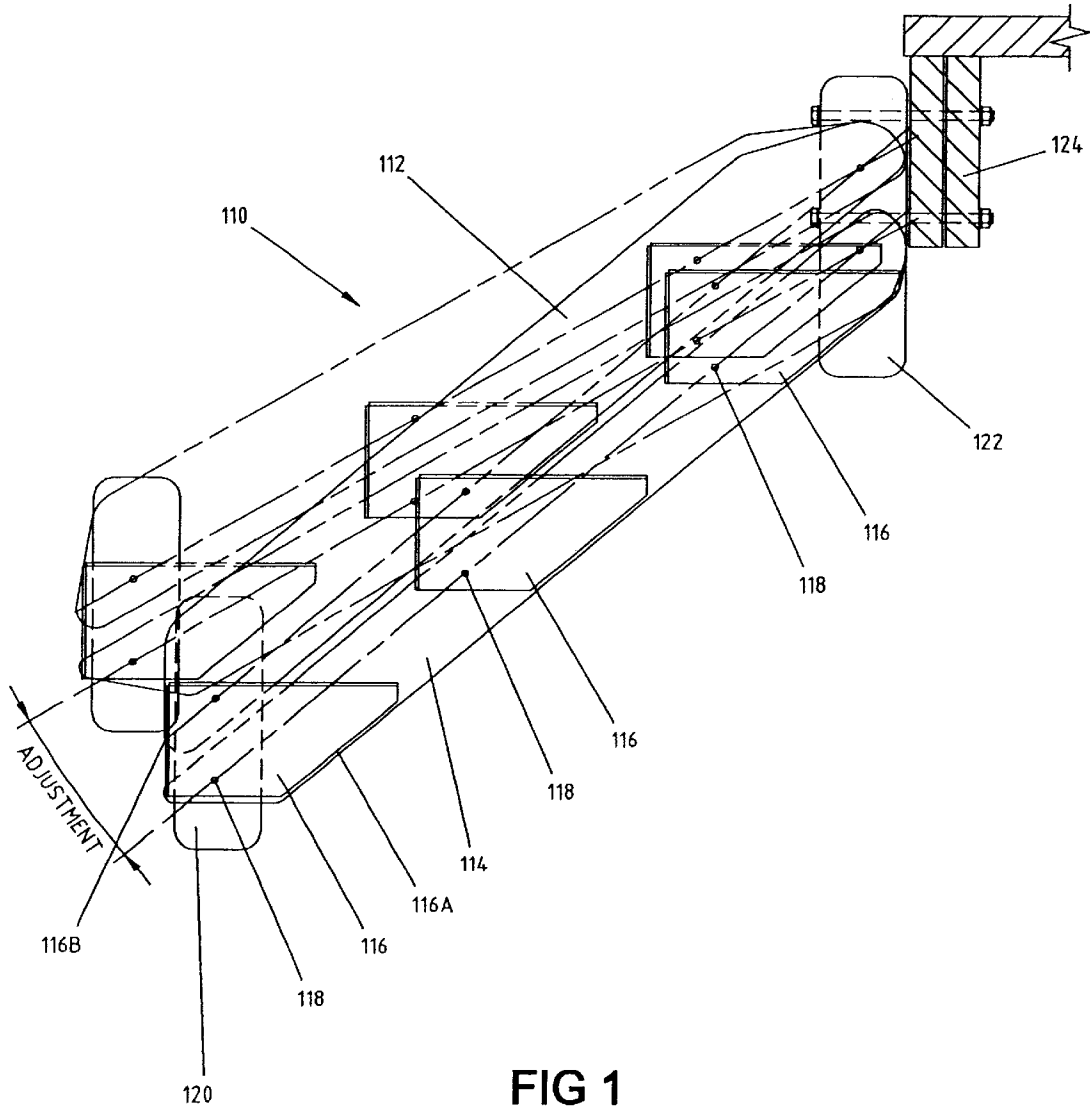

FIG 1

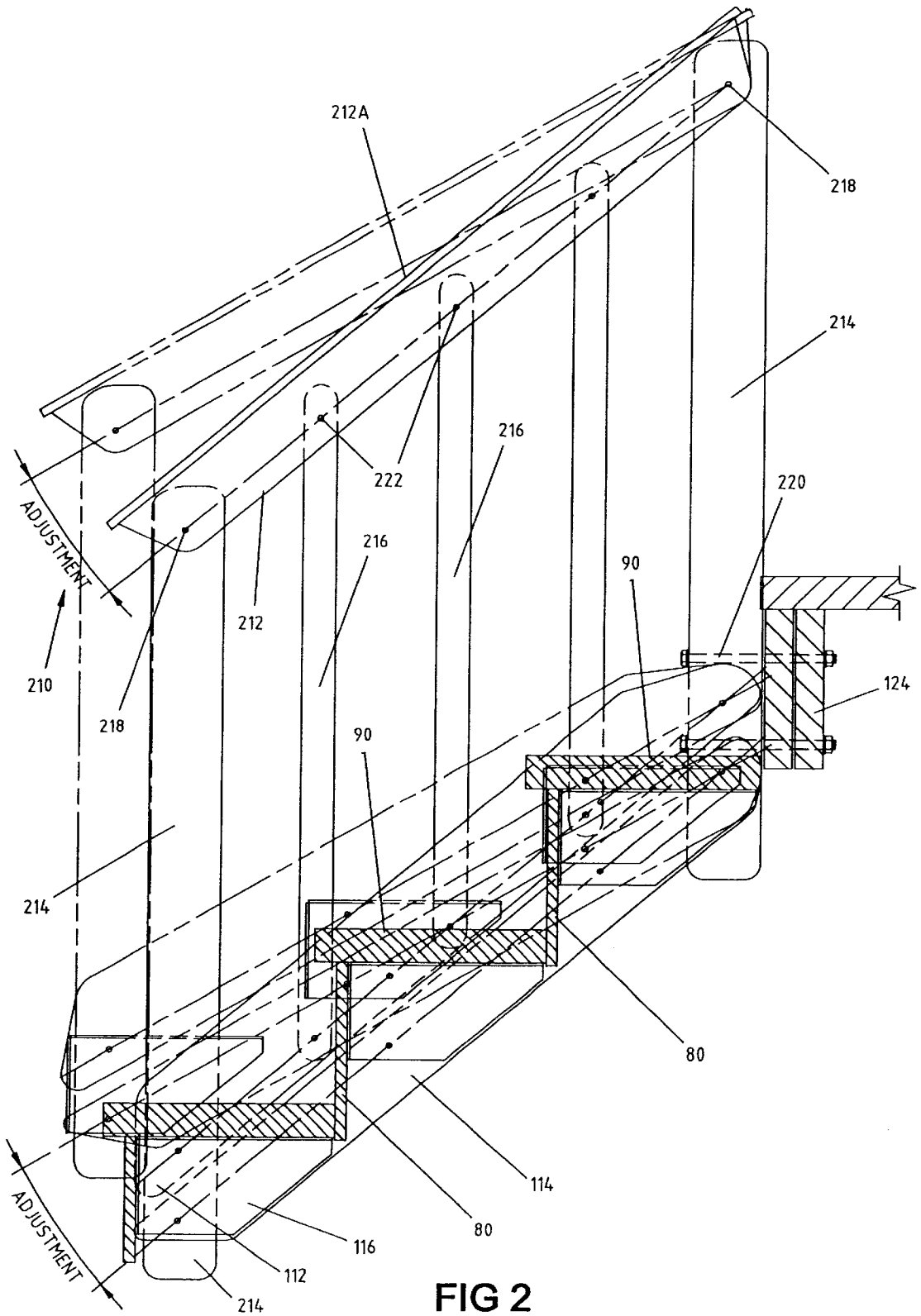

FIG 2

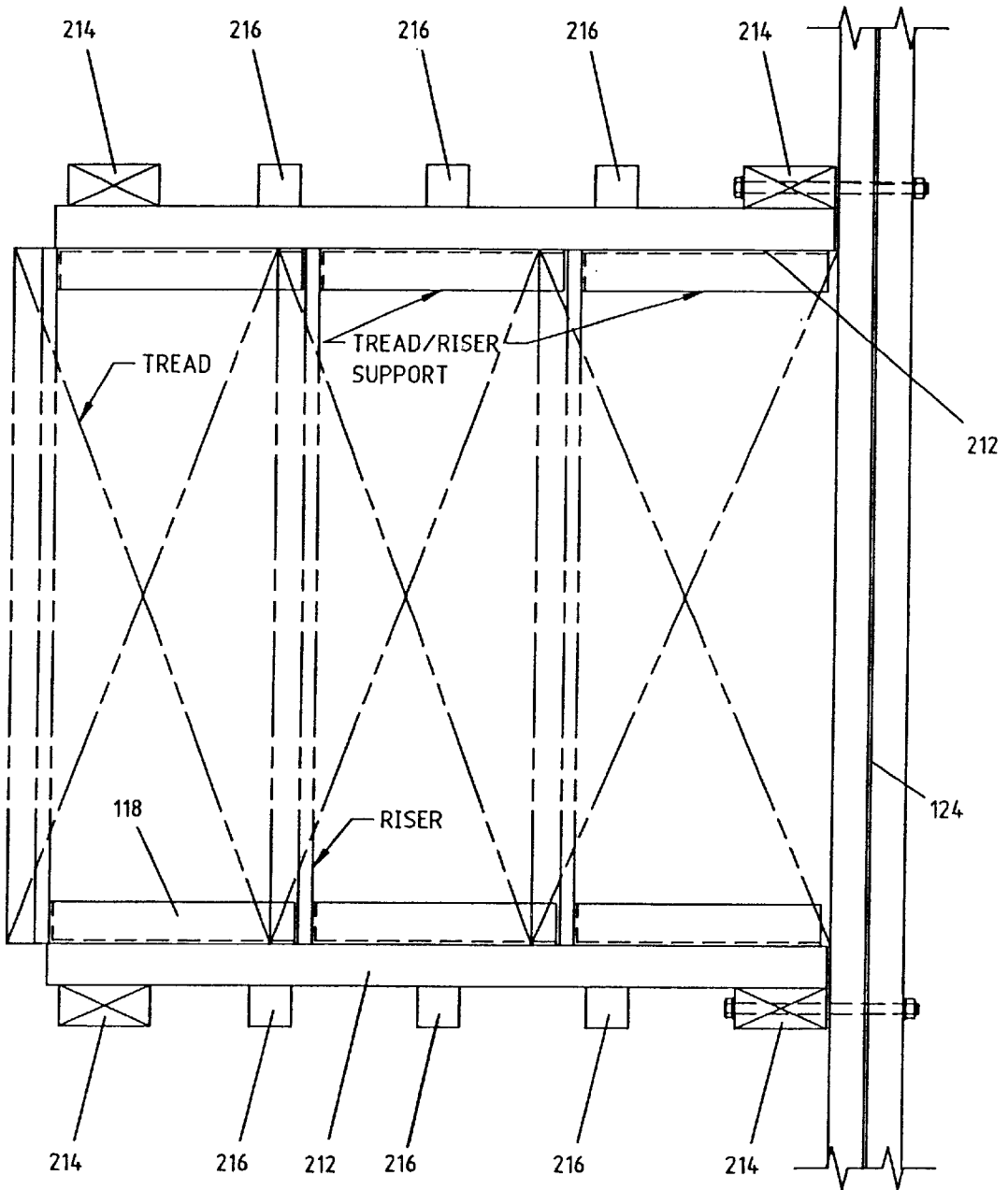

FIG 3

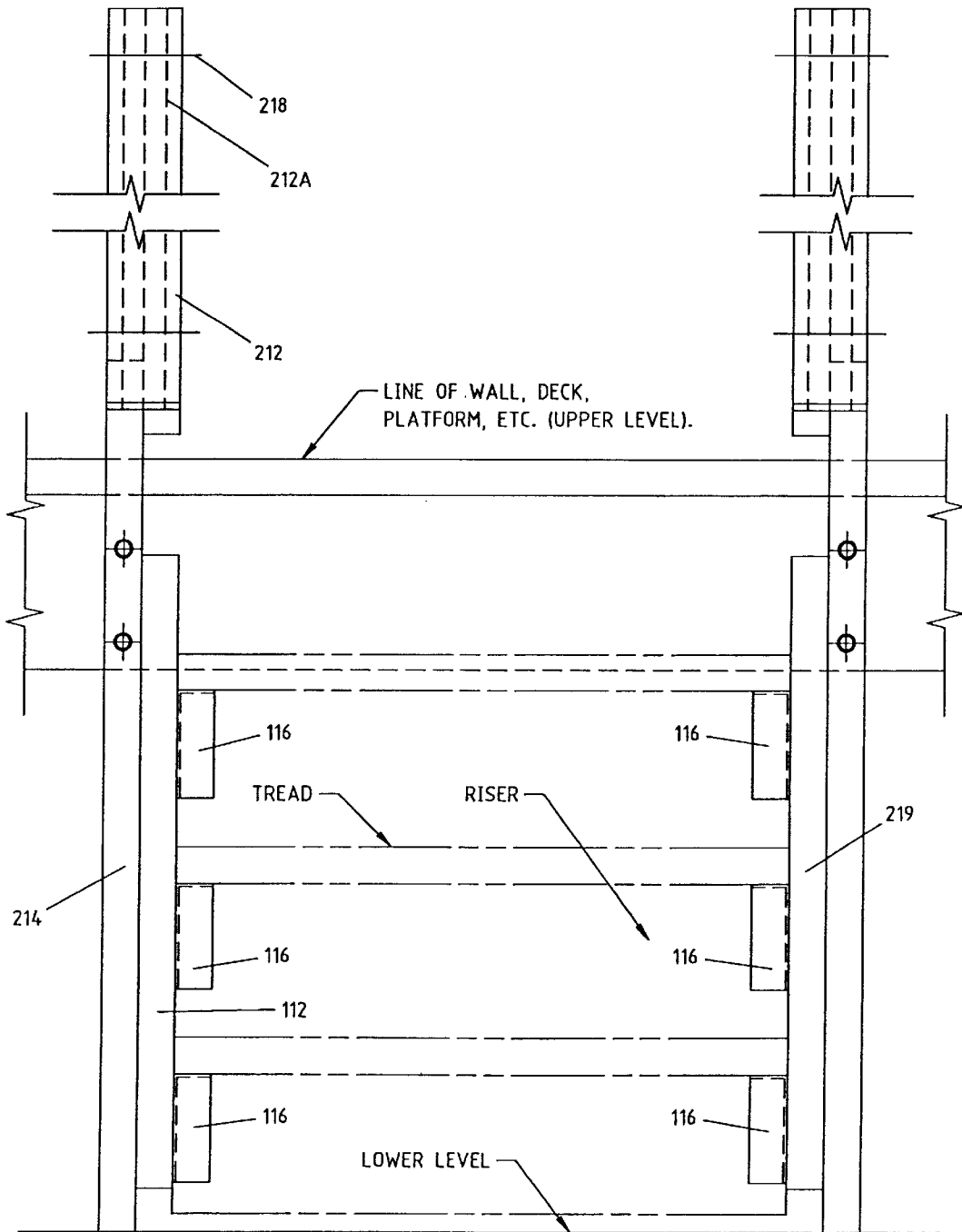

FIG 4

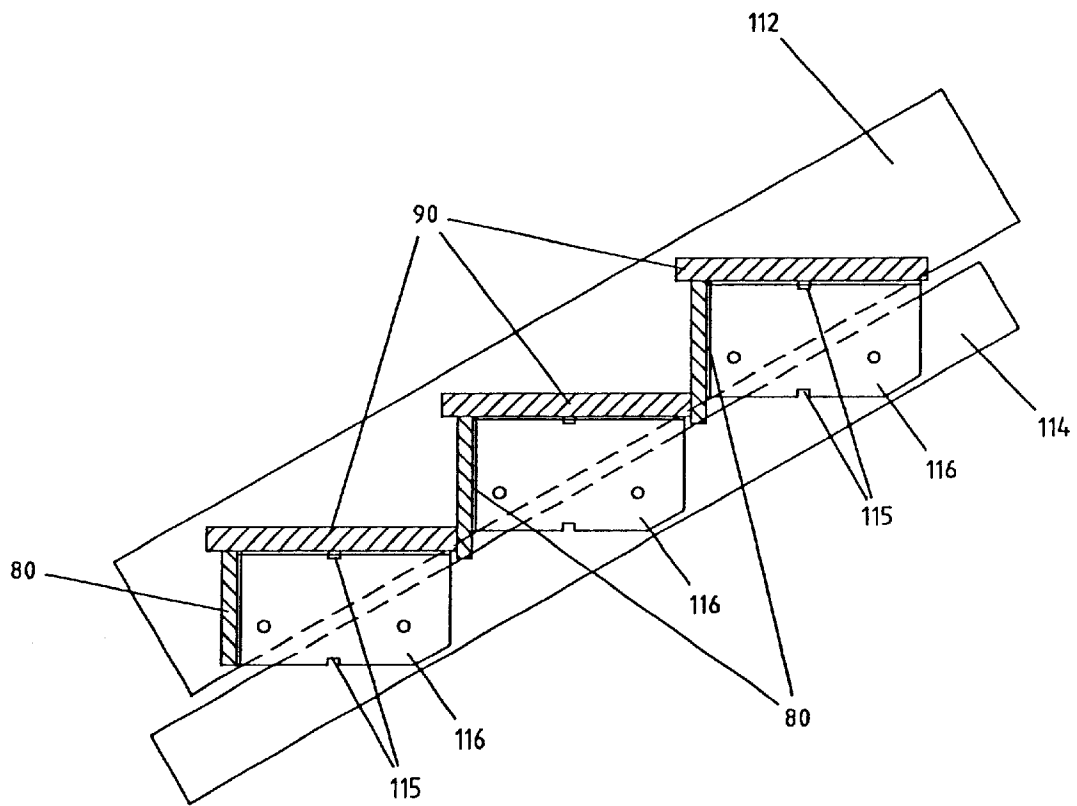

FIG 5

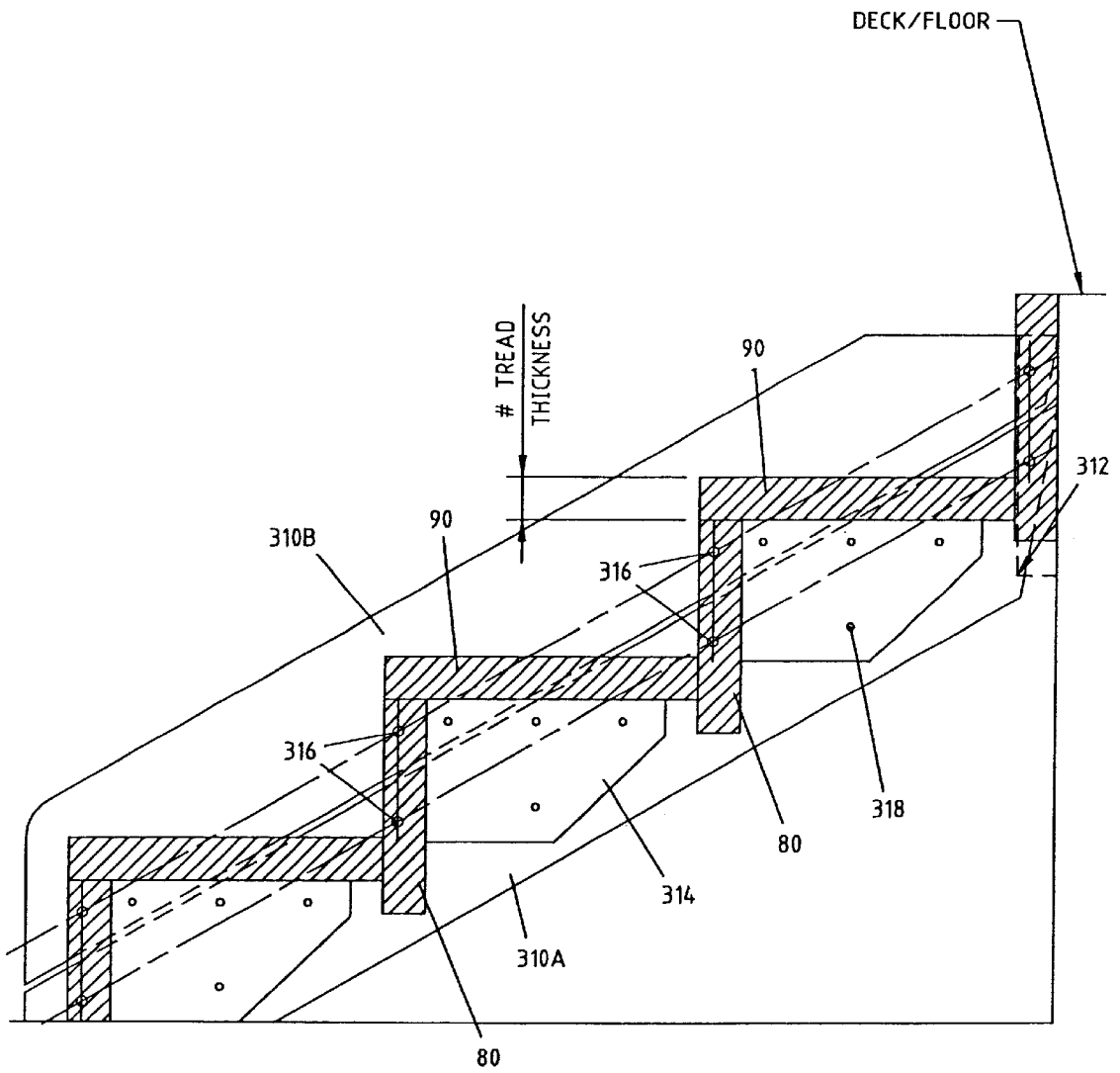

FIG 6

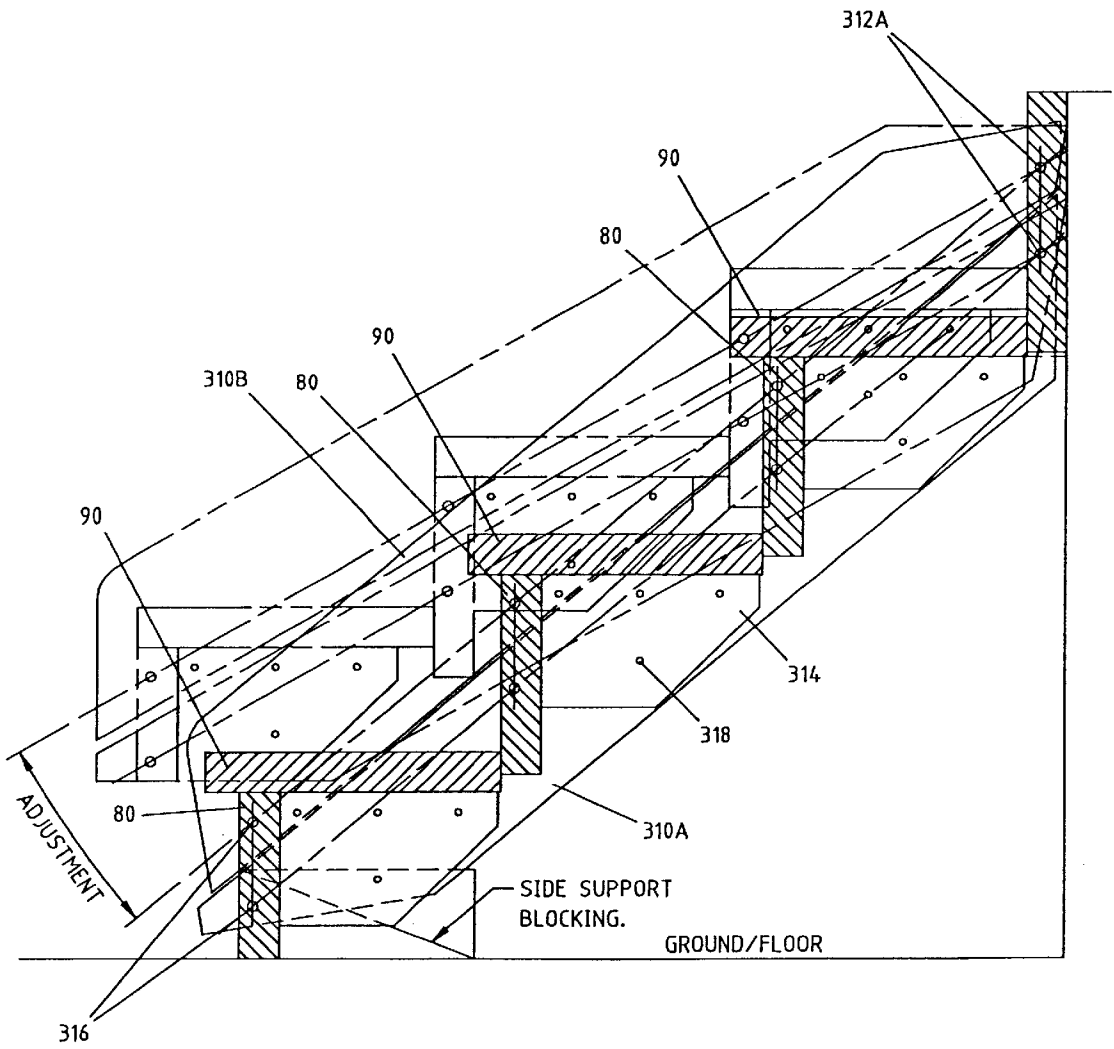

FIG 7

FIG 8

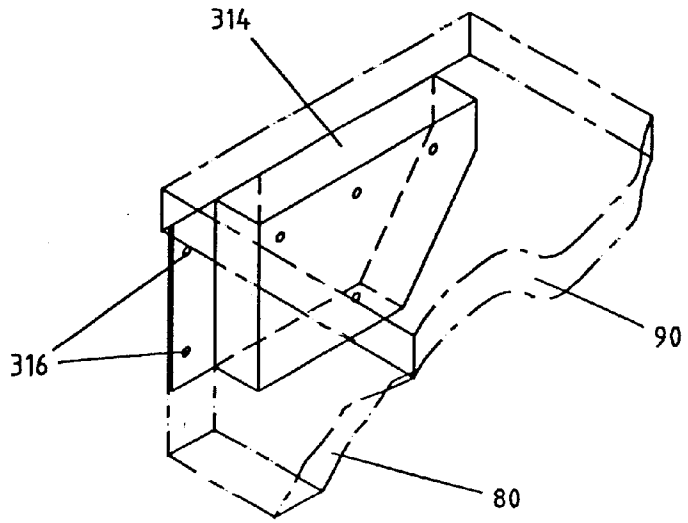

FIG 9

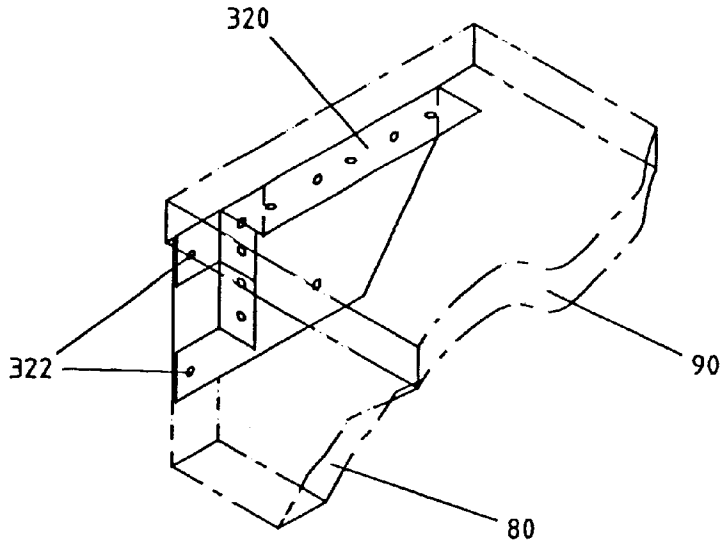
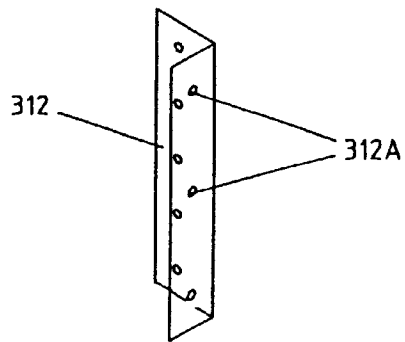

FIG 10



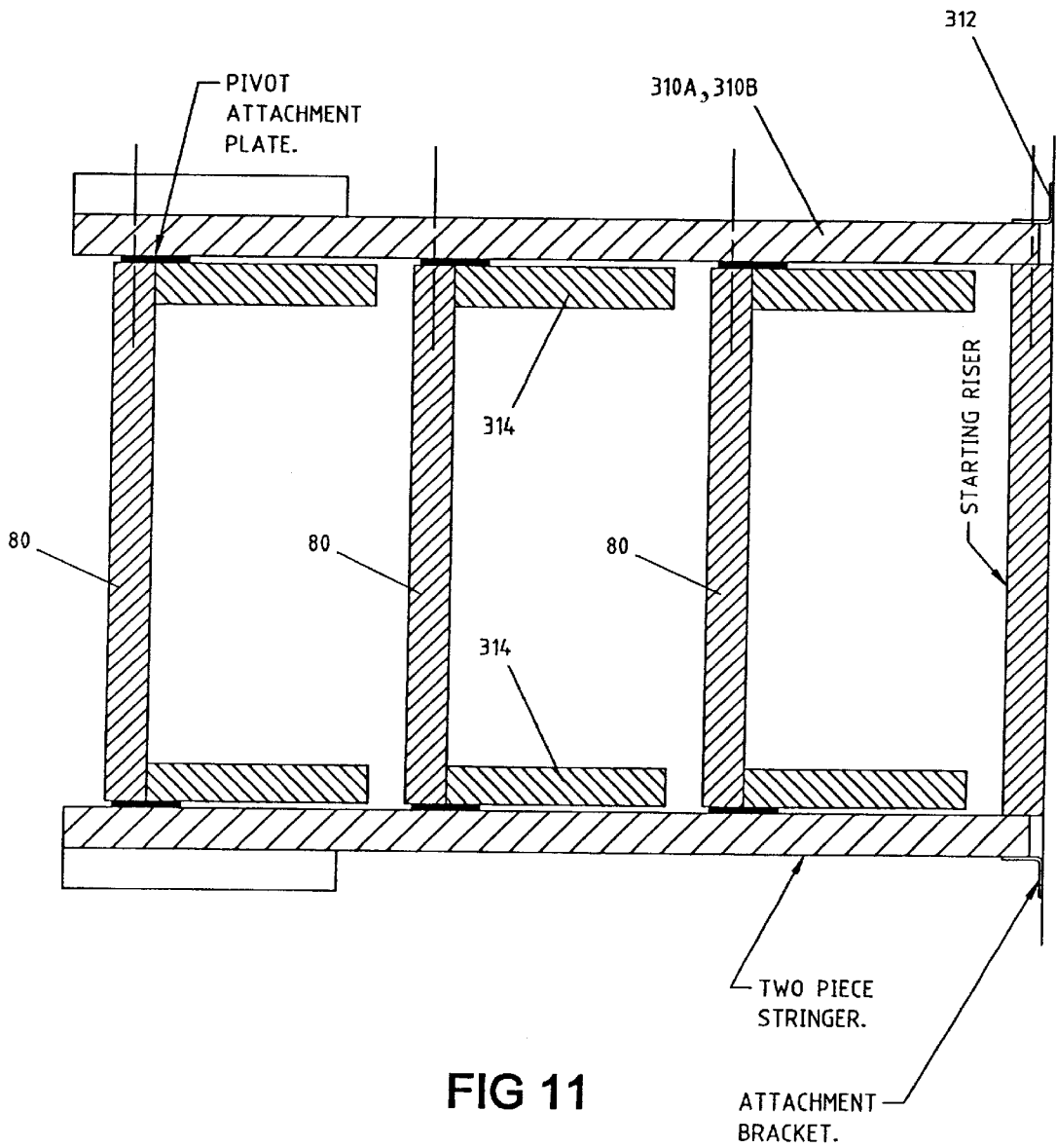

FIG 11

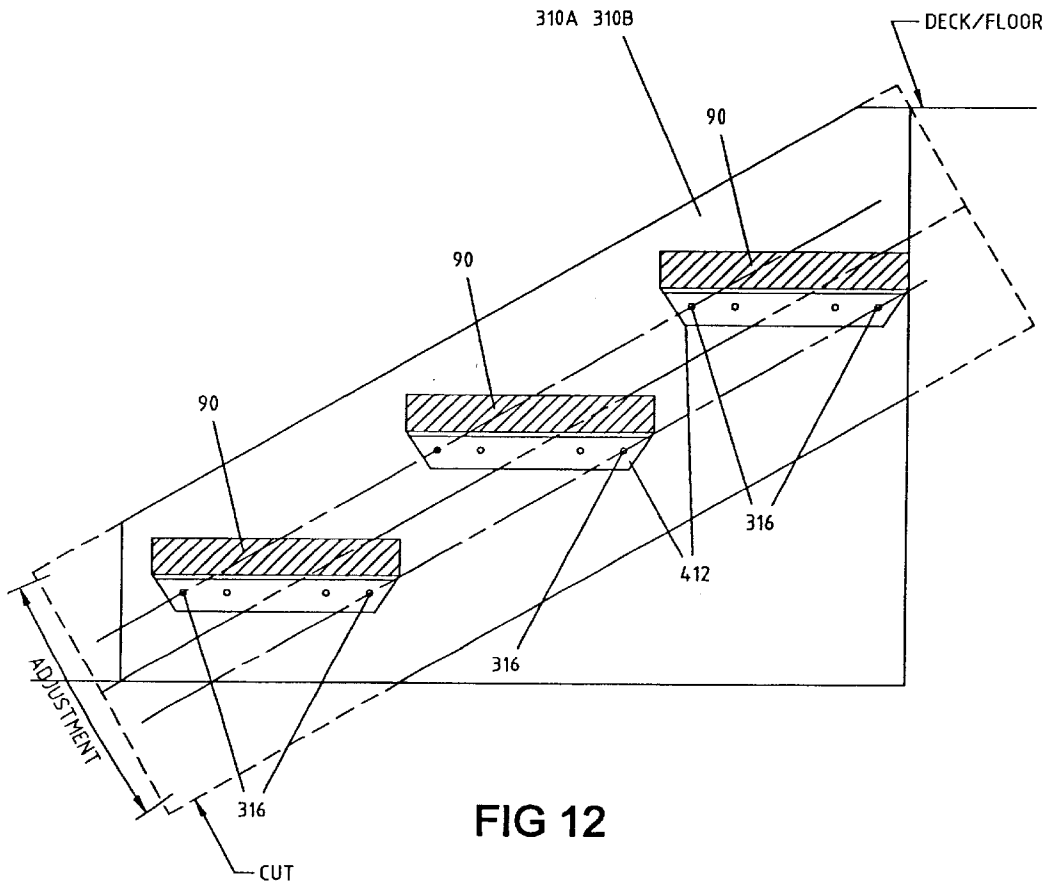

FIG 12

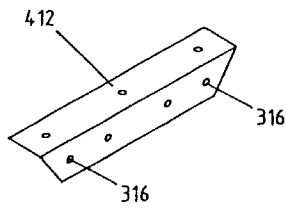

FIG 13

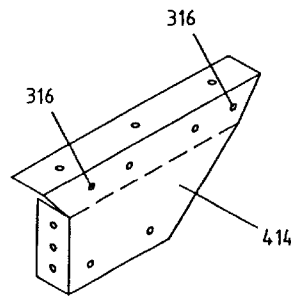

FIG 14

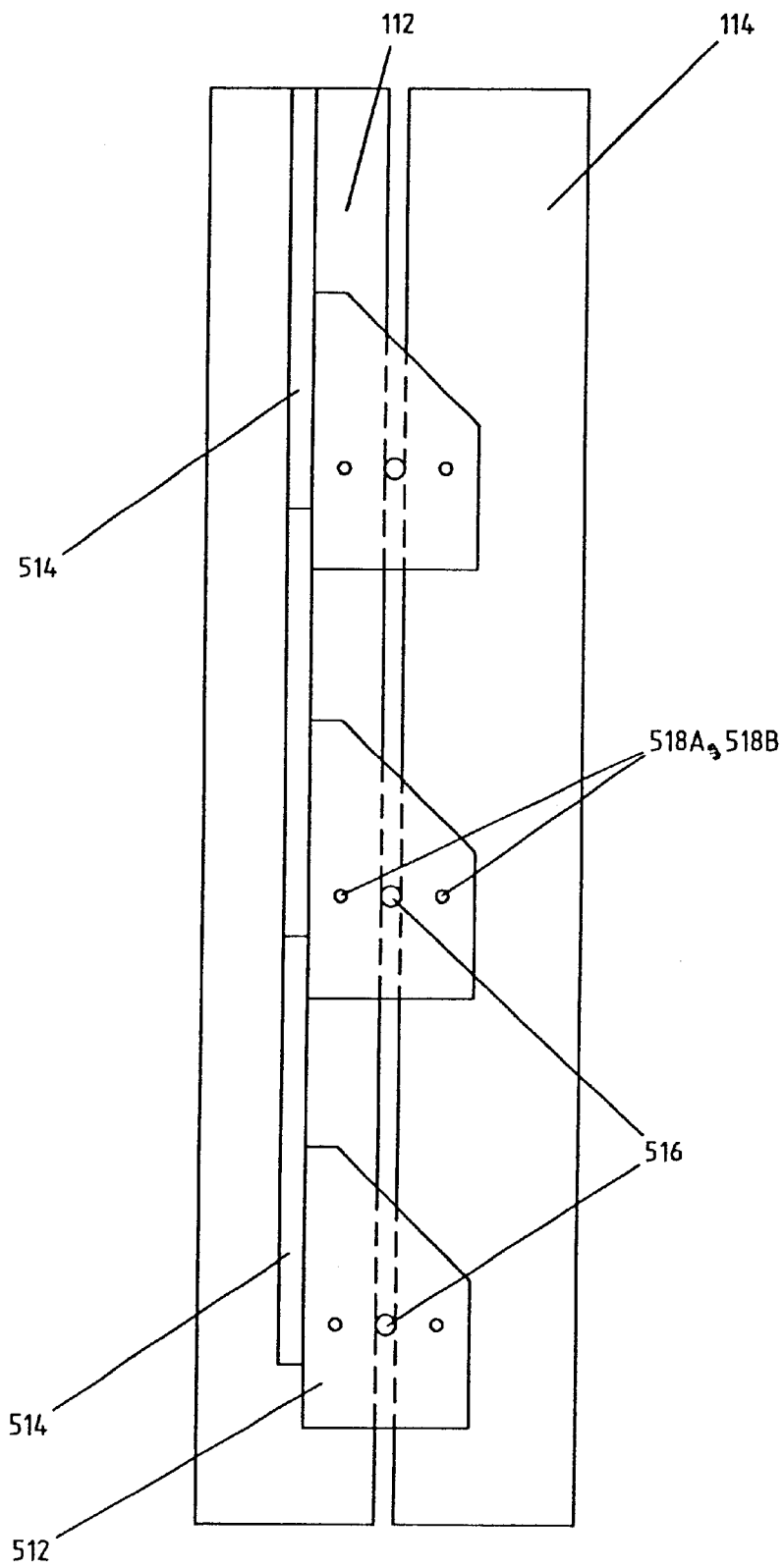

FIG 15

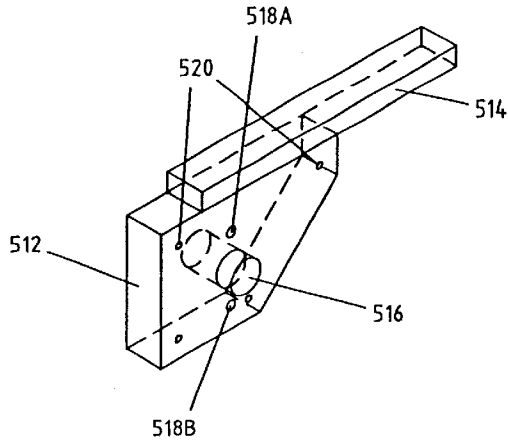

FIG 17

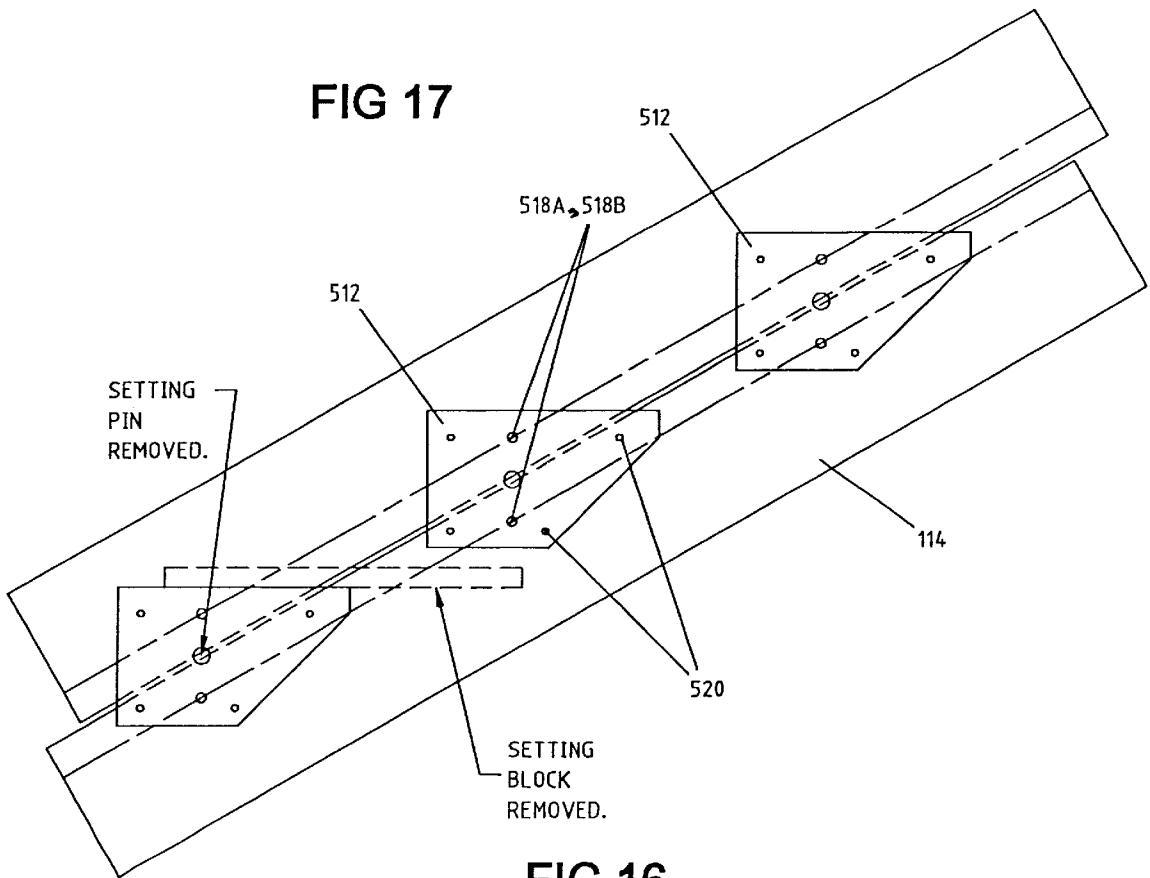

FIG 16

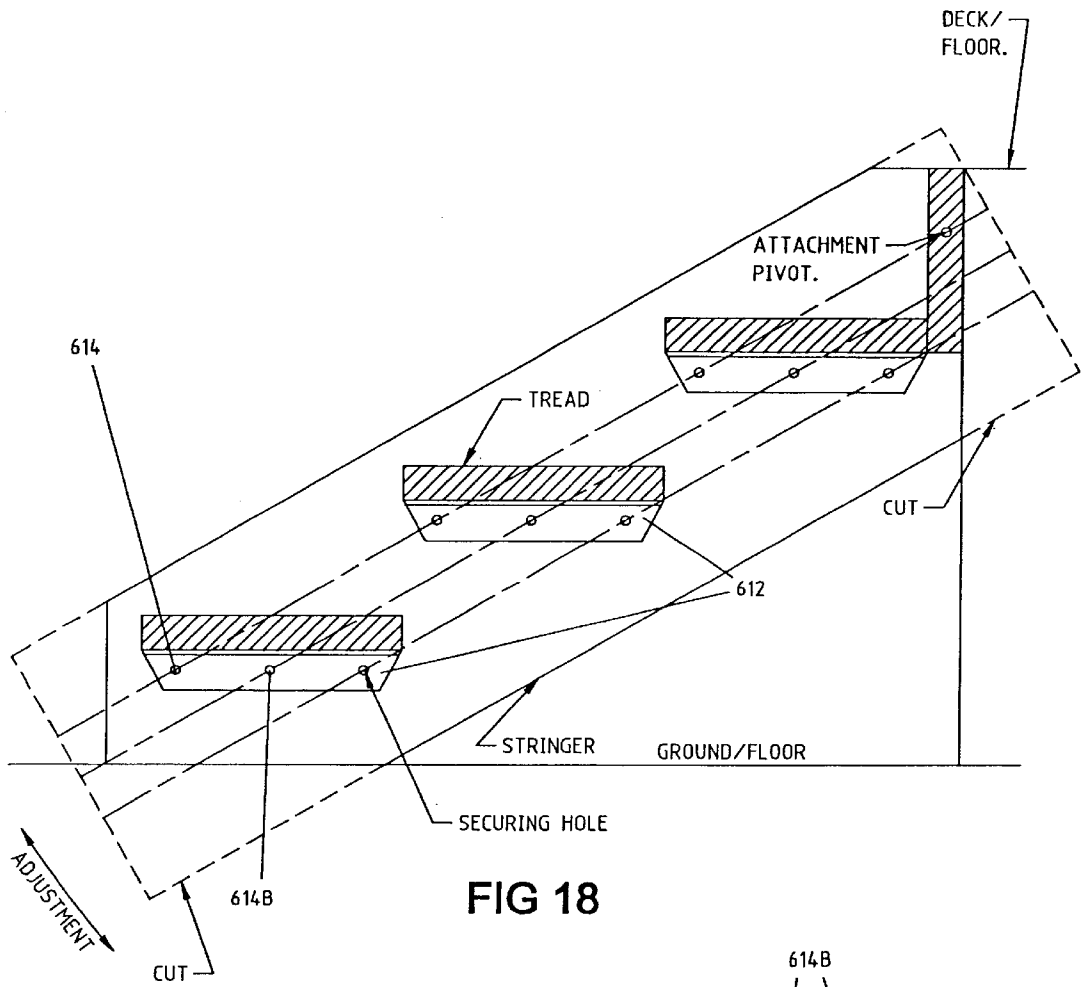

FIG 18

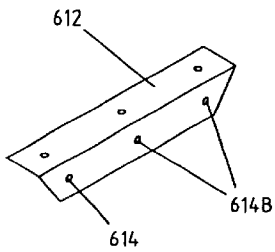

FIG 19

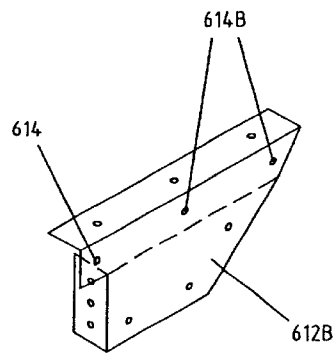

FIG 20

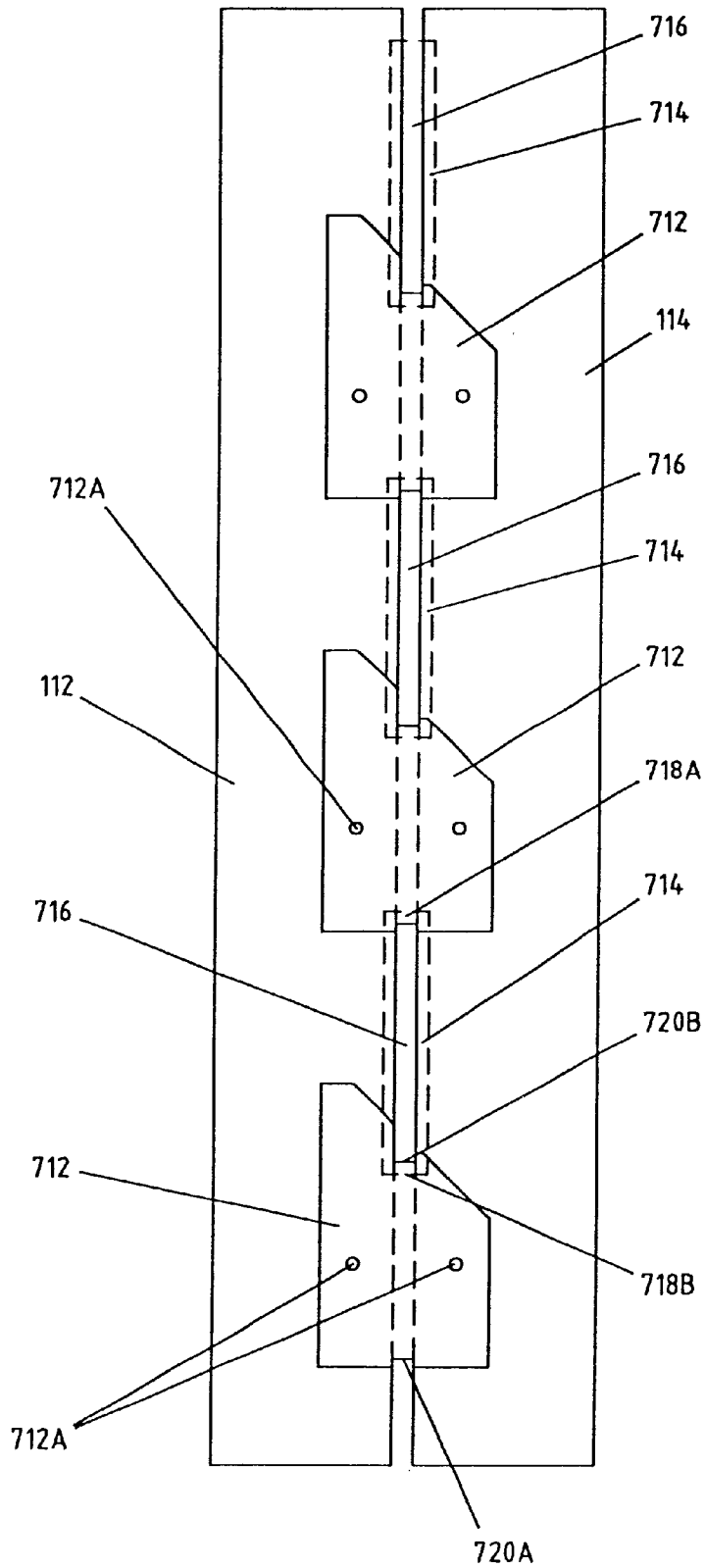

FIG 21

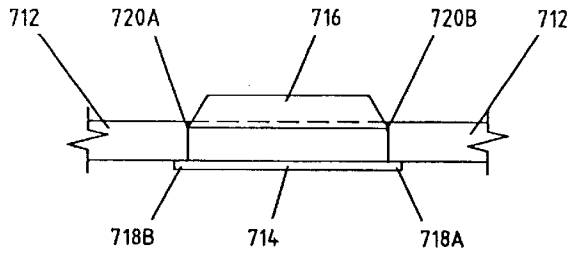

FIG 22

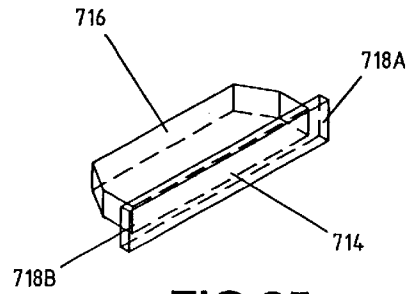

FIG 25

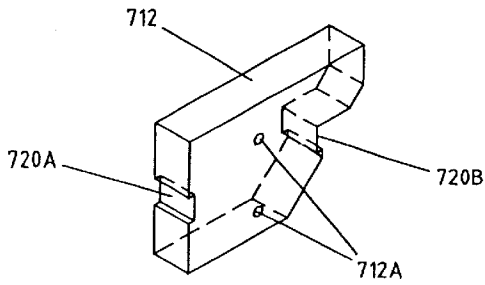

FIG 24

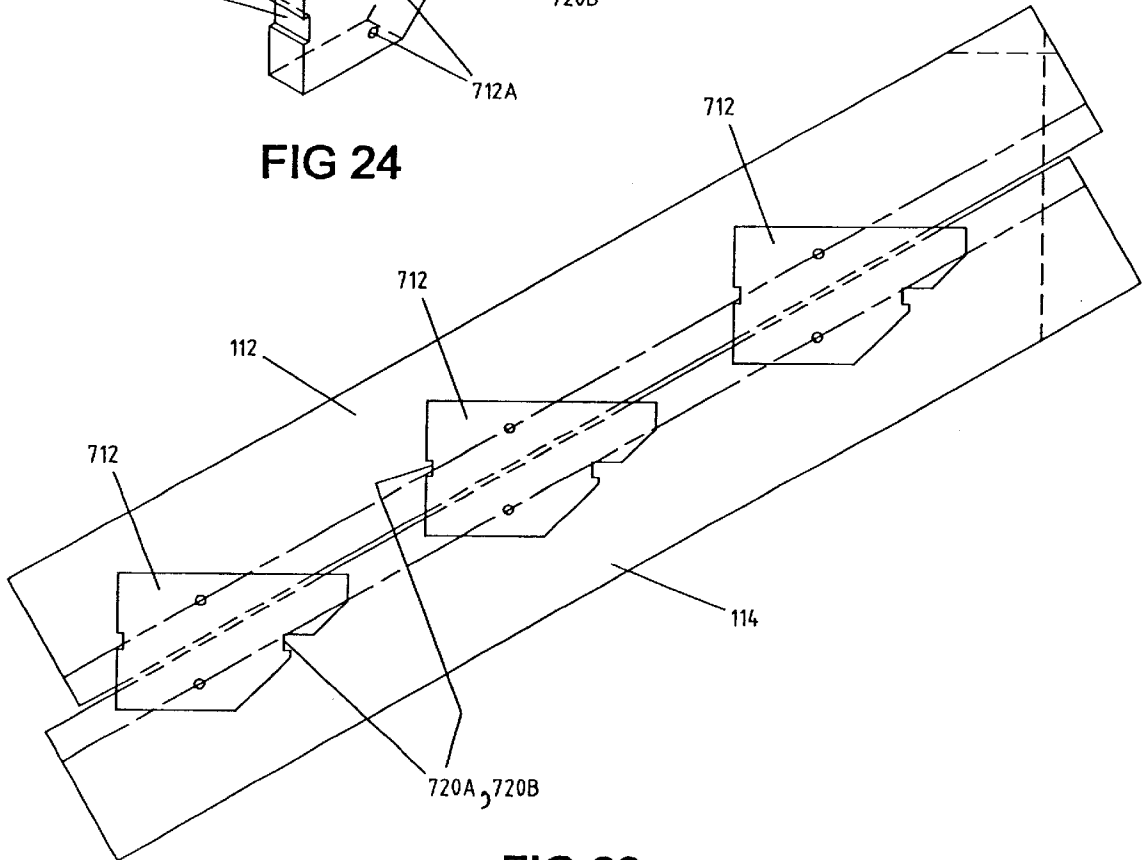

FIG 23

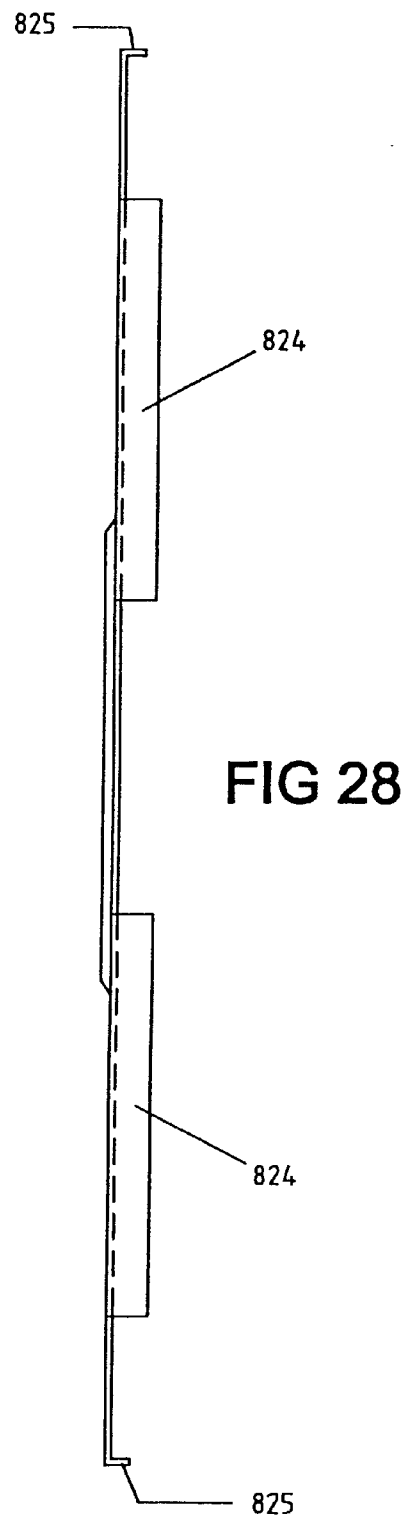
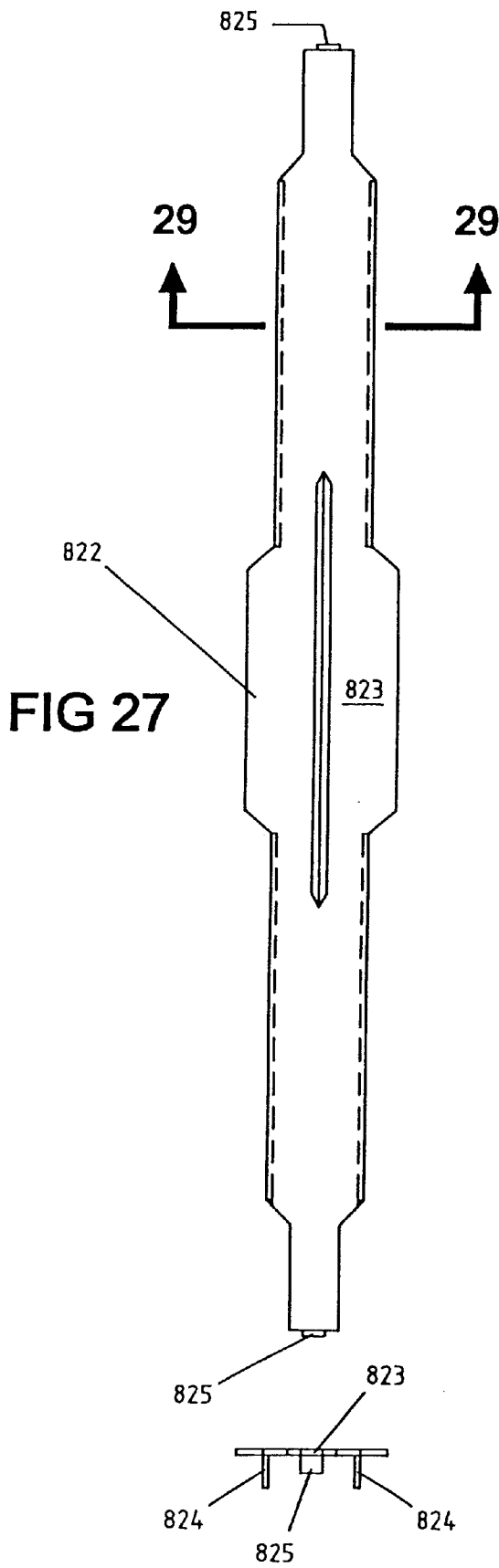

FIG 29

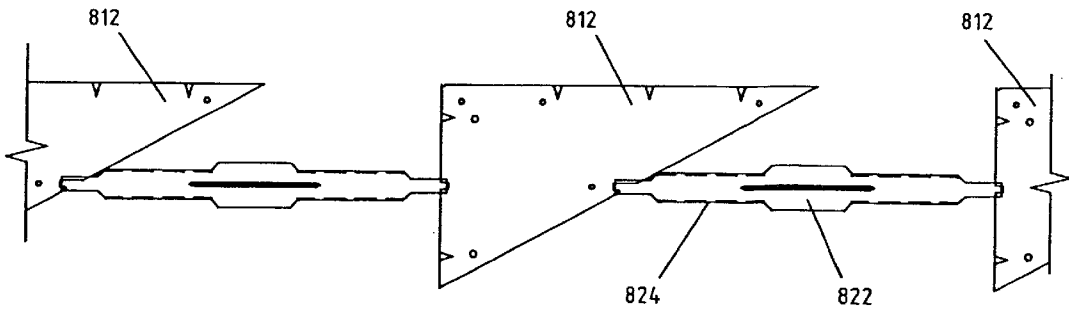

FIG 30

FIG 31

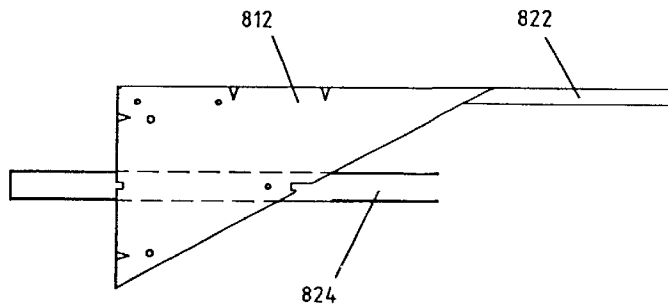

FIG 32

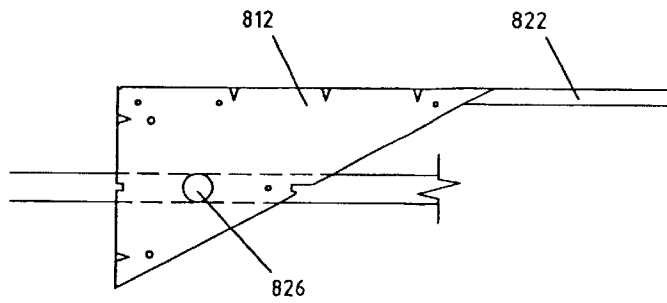
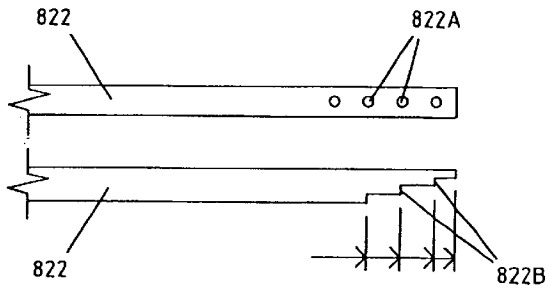
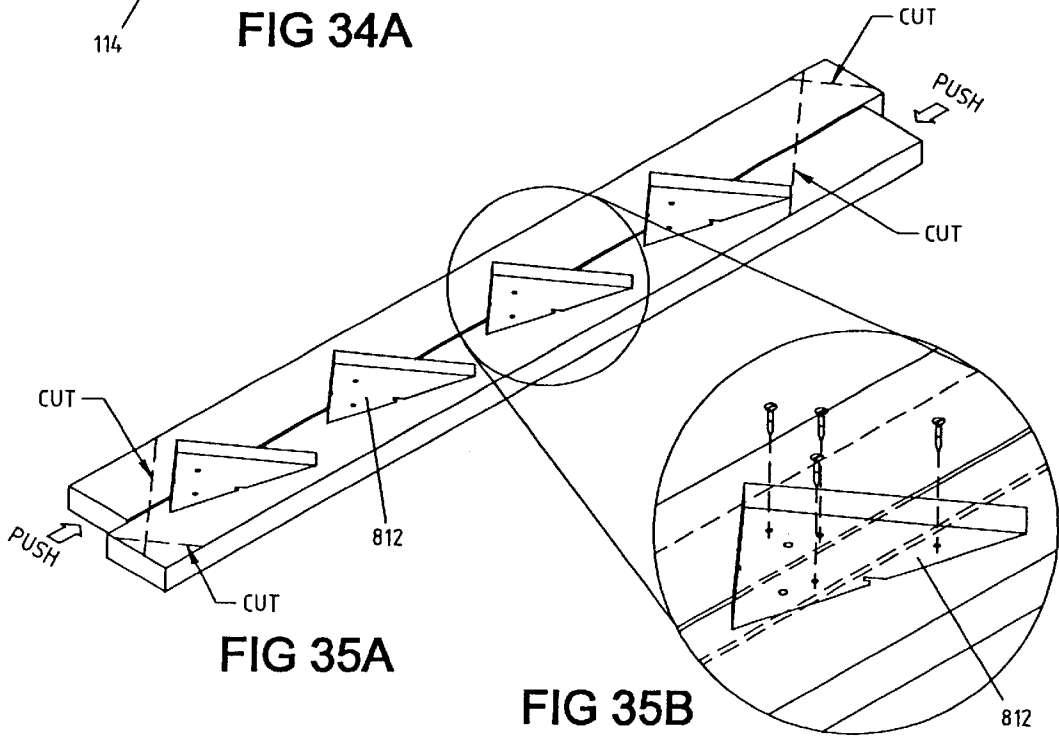
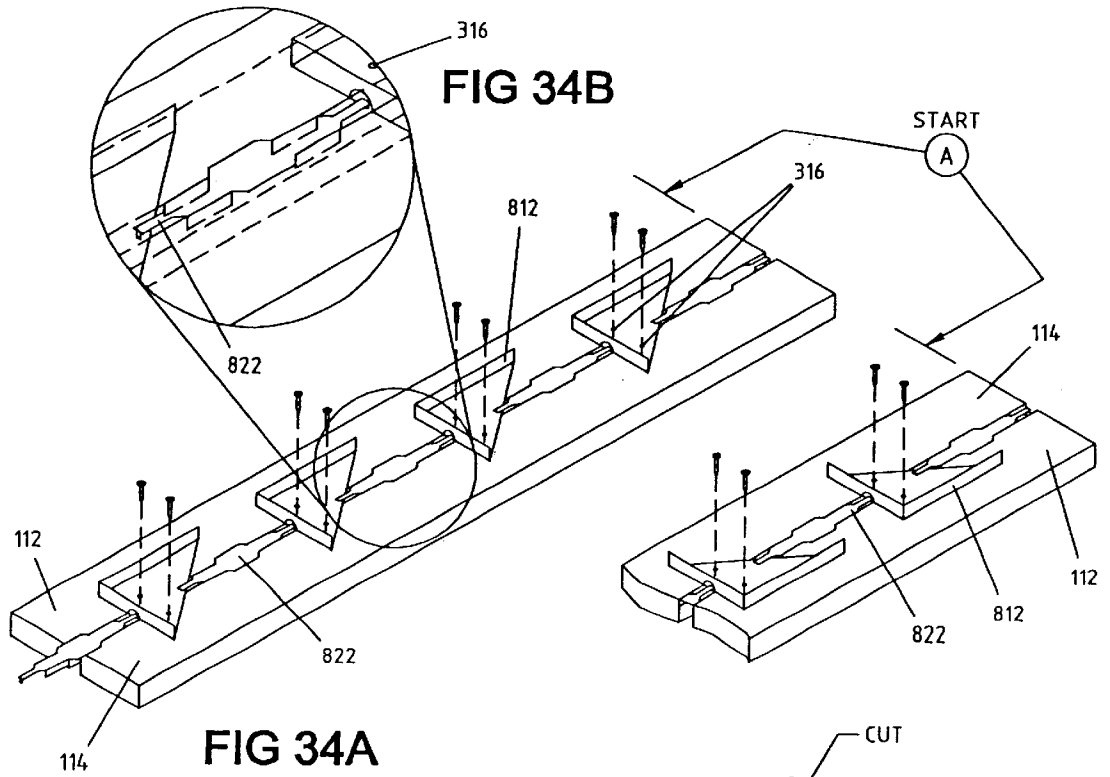

FIG 33





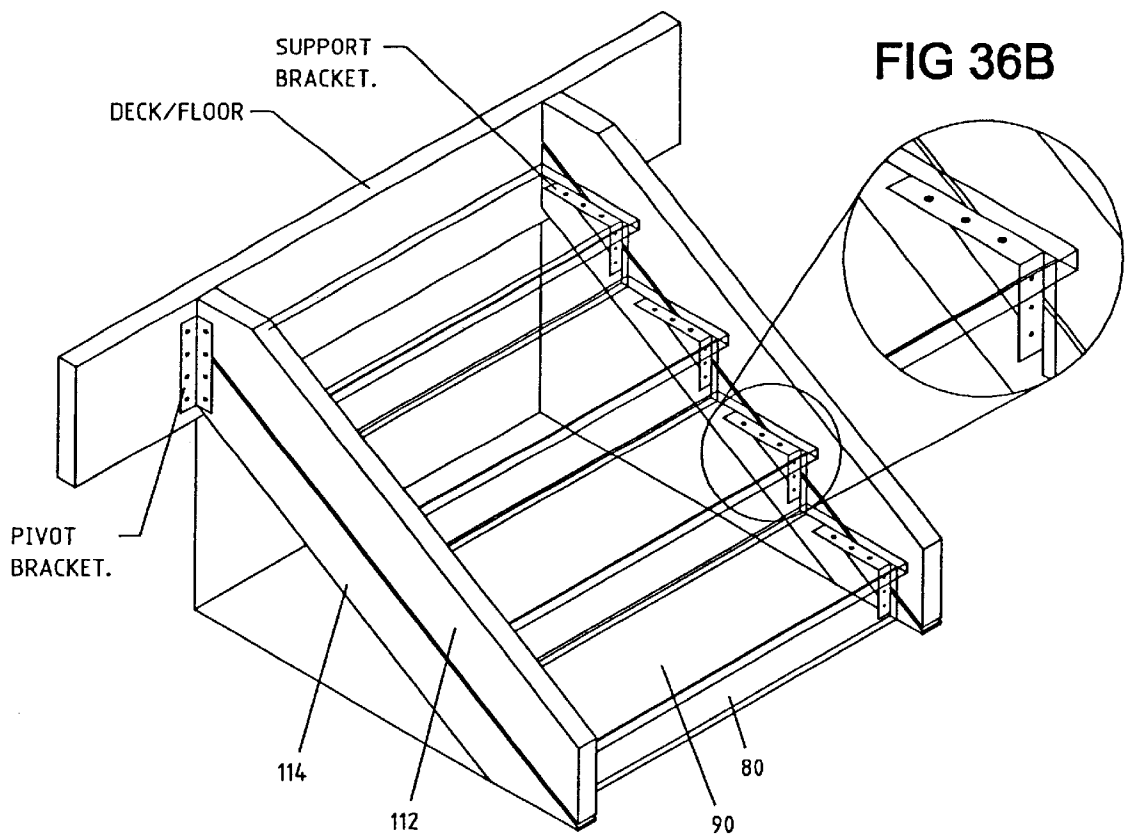
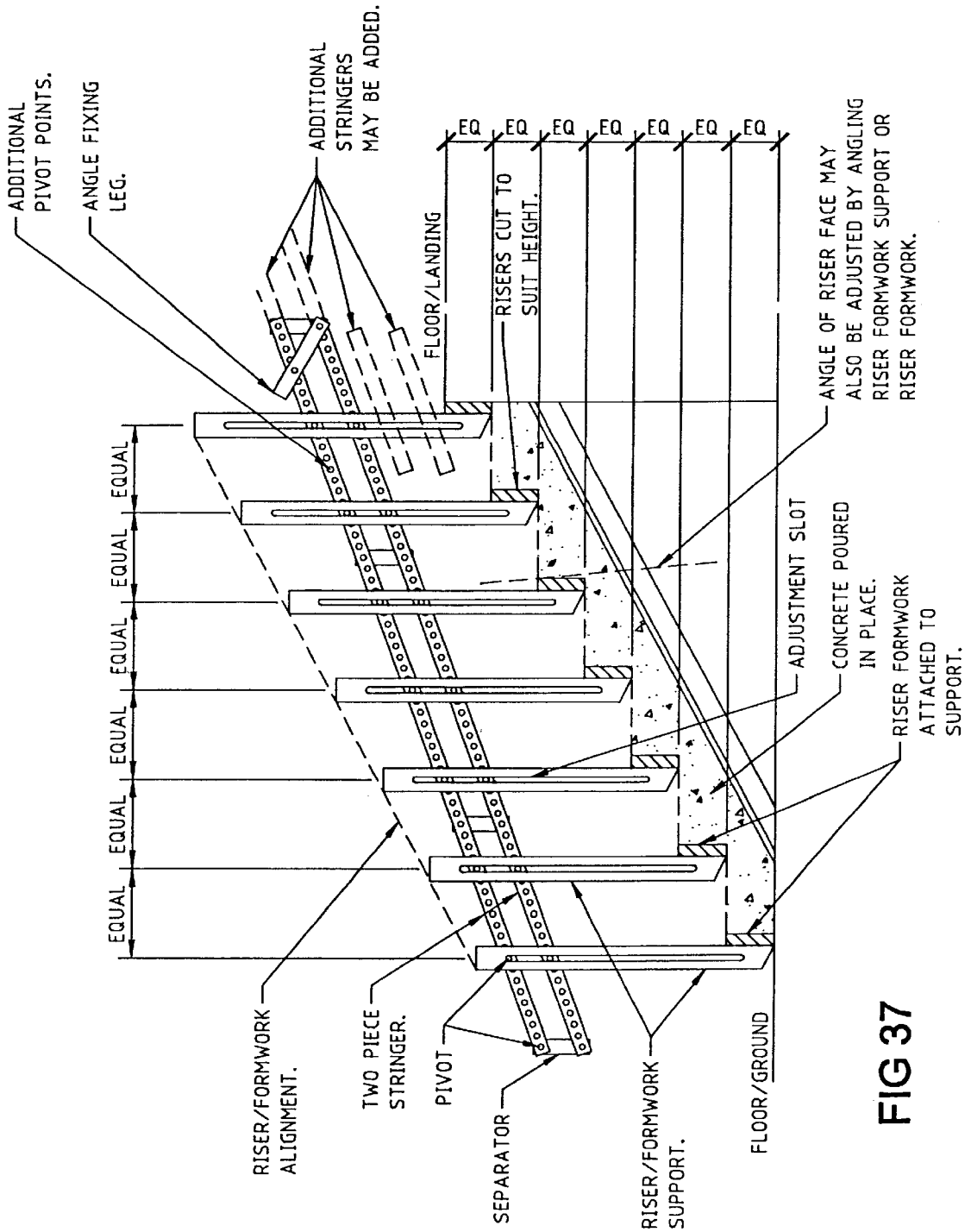

FIG 36A



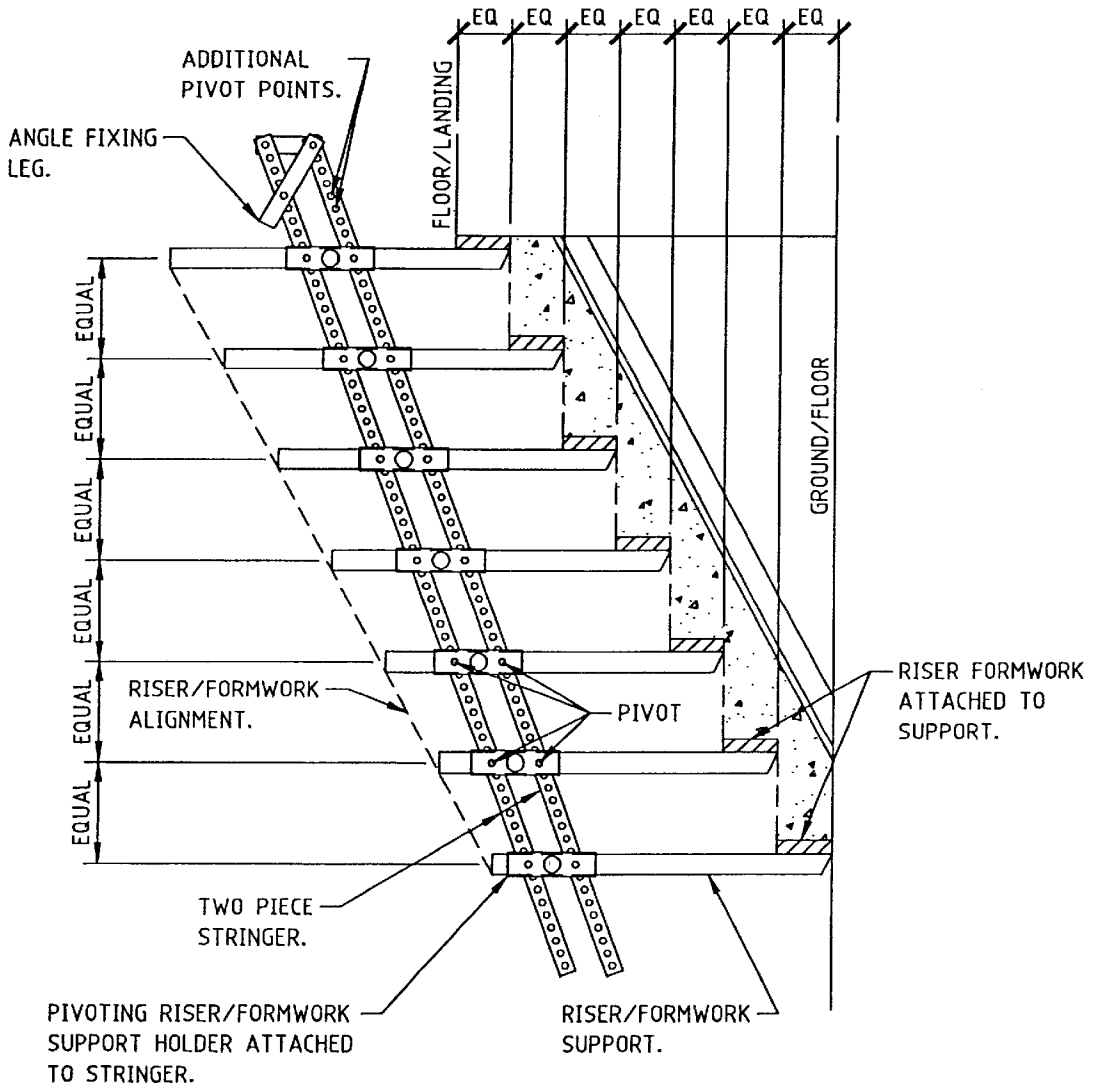

FIG 38A

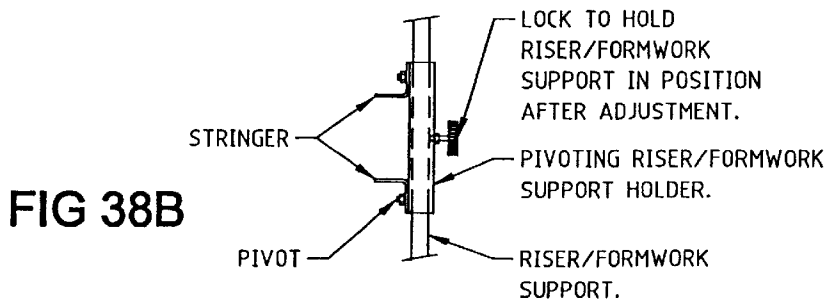

FIG 38B

ADJUSTABLE STAIR STRINGER AND RAILING

This application claims priority from Provisional Application No. 60/085,151 for ADJUSTABLE STAIR STRINGER AND RAILING filed May 21, 1998 by Richard Truckner and Paul Truckner.

Numerous innovations for adjustable stairways have been provided in the prior art that are described as follows. Even though these innovations may be suitable for specific individual purposes to which they address, they differ from the present invention as hereinafter contrasted.

The prior art does not utilize a pivoted motion and does not allow an infinite amount of variable spacings when framing stairs and/or a railing. The present invention allows an infinite amount of variable spacings and use of a pivoting motion.

U.S. Pat. No. 2,245,825 to W. E. Ross teaches a folding stand that has pivoting support but is not based on vertical holes which keep treads in a horizontal position with an infinite amount of variable spacings. Furthermore, the patented invention utilizes different elements from the present invention. Some of the differences are:

- 1) Vertical holes are not important,
- 2) Stair is adjustable into one position only,
- 3) Not meant to be permanently fixed after moved into position on risers,
- 4) Risers and treads to not slide past each other,
- 5) Pivoting tread support is not fixed in position after adjustment and therefore not used to lock stringers.

U.S. Pat. No. 4,370,664 to J. J. Whitehead teaches an adjustable staircase. The patented invention does not have any pivoting motion and utilizes different elements from the present invention.

U.S. Pat. No. 3,885,365 to J. W. Cox teaches a self adjusting stair which utilizes a truss assemblage. In the patented invention adjustments are made using a pin and slot. The patented invention does not utilize any pivoting motion and the rails are not adjusted by stringers as with the present invention.

U.S. Pat. No. 3,962,838 to J. W. Cox teaches a self adjusting stair which utilizes spacers in a truss assemblage. The patented invention does not utilize a pivoting motion and the rails are not adjusted by stringers.

U.S. Pat. No. 4,406,347 to N. M. Strathopoulos teaches a modular staircase assembly. The patented invention does not utilize a pivoting motion. The rails are not adjusted by stringers and are not adjusted on vertical holes.

U.S. Pat. No. 4,959,935 to H. R. Stob teaches a prefabricated adjustable stairway. The patented invention does not utilize a pivoting motion and the rails are not adjusted by stringers. This apparatus uses a three point pivoting action so that stringers do not separate during adjustment and slide one on top of the other.

U.S. Pat. No. 5,189,854 to K. J. Nebel teaches an adjustable height staircase. The patented invention does not utilize a pivoting apparatus as described herein. The present invention utilizes a pivoting apparatus and contains different elements from the patented invention for at least the following reasons:

- 1) Treads are directly connected to stringers,
- 2) No risers,
- 3) No sliding motion of riser past the tread.

U.S. Pat. No. 4,124,957 to Pouplaw shows treads that are directly connected to stringers, stringers that have special tongue and groove spacers which must be an exact size each

time in order to lock stringers otherwise the stringers must be secured top and bottom of the stair only, and risers and treads do not slide past each other.

Numerous innovations for adjustable staircases have been provided in the prior art that are adapted to be used. Even though these innovations may be suitable for specific individual purposes to which they address, they would not be suitable for the purposes of the present invention as heretofore described.

SUMMARY OF THE INVENTION

The structure of the present invention can be used for forming a stair and may also be used as a support for concrete form work, as a form for a ramp, as a form for adjustable shelves, as an adjustable bleacher, and for adjustable displays.

It is an object of the present invention to provide an adjustable stringer and railing that allows users to have a quickly formed stair structure.

It is another object of the present invention to provide an adjustable stringer and railing that provides partially assembled elements that can be adjusted to a variety of applications and then securely fixed to form a stair framing and/or railing framing.

It is another object of the present invention to provide an adjustable stringer and railing that utilizes a pivoting motion.

It is another object of the present invention to provide an adjustable stringer and railing that allows an infinite amount of variable spacings when creating stairs and/or railing.

It is another object of the present invention to provide an adjustable stringer and railing that eliminates the need to calculate spacing between step treads and angle of the stairs.

It is another object of the present invention to provide an adjustable stringer and railing that provides an embodiment that includes an upper stringer arm, a lower stringer arm and at least one riser support.

It is another object of the present invention to provide an adjustable stringer and railing that provides an embodiment that includes an upper rail support and at least two railing posts pivotally attached to the upper rail support.

It is another object of the present invention to provide an adjustable stringer and railing that is easy and inexpensive to manufacture.

Another object of the present invention is the use of a bracket and setting and spacer bar that can be used with stringer elements for simplifying the formation of a stair assembly with treads, risers and rail supports.

Further objects of the present invention include a stair forming apparatus that includes a pivoting block to which treads and risers can be attached, a pivoting block to which treads only can be attached, a pivoting block which allows risers and treads to slide past each other, a pivoting block which allows risers and treads to be attached such that the risers and treads can be attached to each other after assembly to form a solid construction in which the risers become beams and the treads become lateral bracing to produce great structural strength and much wider stair widths than normal with on center supports (additional stringers) as with normal stairs, and greater stringer strength than with normal saw tooth stringers because of greater stringer depth and, when the riser/tread supports are secured to the upper and lower stringers after adjustment, the stringers are bonded together to form one solid stringer which also is capable of much greater spans without additional supports.

The structure of the present invention includes riser and tread support which allows risers and tread to slide past each other (as the stinger is adjusted) in order to utilize standard lumber and eliminate the need to cut lumber to exact widths, to use standard lumber of varying lengths according to width of the stair (i.e. 4' to 10' wide stairs), to use riser and tread support systems which, after pivoting and adjusting in position, allows risers to be used as beams which greatly increases the structural strength of the stair allowing much greater stair widths than normal without the need for additional center support stringers, and provides a stringer system which, when the riser/tread supports are secured, the stringer members are bonded together to form a much stronger stringer member than in normal "saw tooth" type construction giving much greater stair lengths without additional supports.

The foregoing benefits are accomplished with the use of a simplified bracket, spacer and setting combination that permits the assembly of a stair stringer assembly without difficulty permitting the "do it your-selfer" to install a stair assembly with simple instructions.

BRIEF DESCRIPTION OF THE DRAWINGS

FIG. 1 is a side view of the stair embodiment of the adjustable stair stringer and railing illustrating two possible inclinations.

FIG. 2 is a side view of the railing embodiment of the adjustable stair stringer and railing.

FIG. 3 is a top view of the adjustable stair stringer and railing.

FIG. 4 is a front view showing the assembled stair and railing set in position.

FIG. 5 is a side view showing the assembled stairs.

FIG. 6 is a side view of an alternative form of the adjustable stair as assembled.

FIG. 7 is a side view showing the adjustable stair in two alternative rise angles using the same elements.

FIG. 8 is a perspective view showing the nailing block and pivot attachment plate for the stair assembly of FIG. 7.

FIG. 9 is a perspective view of an alternative riser tread support.

FIG. 10 is a perspective view of the attachment bracket as used in the present invention.

FIG. 11 is a top plan view of a stair assembly of the form of FIG. 7 with risers and without the treads.

FIG. 12 is a sectional view of a stair assembly of the form of FIG. 7 with the use of horizontal pivots.

FIG. 13 is a perspective view of the tread support bracket as used in FIG. 12.

FIG. 14 is an alternative form of a tread support and riser support using horizontal pivots as used in FIG. 12.

FIG. 15 is an elevation view showing alternative riser/tread supports which are individually set on a two piece stringer.

FIG. 16 is an elevation view showing the riser/tread supports adjusted in position.

FIG. 17 is a perspective view of the riser/tread support of FIGS. 15 & 16.

FIG. 18 is an alternative form of the present invention using a single pivot point for a riser/tread support.

FIGS. 19 & 20 are alternative forms of tread support and riser support for the assembly of FIG. 18.

FIG. 21 is a side elevation view with an alternative stair assembly showing riser/tread supports and setting spacing blocks.

FIG. 22 is a partial top plan view of a portion of FIG. 21.

FIG. 23 is a side elevation view of the alternative riser/tread supports of FIG. 21 after removal of the setting/spacing blocks and as set for assembly as a stair riser and tread support.

FIGS. 24 and 25 are perspective views of the riser/tread support and setting/spacing block after separation.

FIG. 26 is a top plan view of a structure from which a bracket may be formed.

FIG. 27 is a top plan view of a setting and spacer bar for use with the bracket of FIG. 26.

FIG. 28 is a side elevation view of FIG. 27.

FIG. 29 is a sectional view taken along the lines 29—29 of FIG. 27.

FIGS. 30, 31 and 32 are alternative forms of bracket elements with setting/spacing bars.

FIG. 33 is a view showing alternative adjustable spacing constructins.

FIGS. 34A, 34B, 35A, 35B, 36A and 36B illustrate the use of the brackets, setting/spacer bars and stringer elements of the present invention.

FIGS. 37, 38A and 38B are side elevation views of riser formwork and locking clamp using a two piece stinger and riser/formwork supports.

DETAILED DESCRIPTION OF EMBODIMENTS

Referring to FIG. 1 which is a side view of the stair embodiment of an adjustable stair stringer and railing 110 which includes an upper stringer arm 112, a lower stringer arm 114 and at least one riser/tread support 116. The upper stringer arm 112 is parallel to the lower stringer arm 114. The riser/tread support 116 is pivotally attached to the upper stringer arm 112 and pivotally attached to the lower stringer arm 114. The riser/tread support 116 may be attached to the upper stringer arm 112 and lower stringer arm 114 by riser/tread stringer arm fasteners 118. The riser/tread stringer arm fastener 118 can be a pin, screw, bolt, clamp, dowel or hook.

The riser/tread support 116 can be in the shape of a rectangle, square, triangle, pentangle or circle. The riser/tread support 116 may be rectangular in shape and contain a riser/tread support beveled corner 116A. Furthermore, if there are more than one riser/tread supports 116 the riser/tread supports 116 can be positioned equally along the upper stringer arm 112 and lower stringer arm 114. The riser/tread support 116 can be attached at horizontally positioned fixed points 116B fastened to the upper stringer arm 112 and lower stringer arm 114.

The stair embodiment of the adjustable stair stringer and railing 110 can include a lower stringer support 120 which can be attachable to the upper stringer arm 112 and the lower stringer arm 114, and an upper stringer support 122 which can be attachable to the upper stringer arm 112 and the lower stringer arm 114.

The stair embodiment of the adjustable stair stringer and railing 110 can be manufactured from wood, fiberglass, metal, metal alloys, epoxy, carbon graphite, concrete or plastic. It further can be adapted for use to pour concrete and create concrete stairs.

The railing embodiment of the adjustable stair stringer and railing 210 as shown in FIG. 2 showing risers 80 and treads 90 contains an upper rail support 212 and at least two railing posts 214. The two railing posts 214 are pivotally attached to the upper rail support 212. The at least two

railing posts **214** are pivotally attached to the upper rail support **212** by upper rail support railing posts fasteners **218**. The upper rail support railing post fastener **218** can be a pin, screw, bolt, clamp, dowel or a hook.

The railing embodiment of the adjustable stair stringer and railing **210** can contain at least one banister **216** pivotally attachable and/or attached to the upper rail support **212**. The at least one ballister **216** is parallel to the railing posts **214**. The banister **216** can be attached to the upper rail support **212** by an upper rail support banister fastener **222**. The at least one banister **216** can be positioned equally along the upper rail support **212**. The upper rail support banister fastener **222** can be a pin, screw, bolt, clamp, dowel or hook.

The rail embodiment of the adjustable stair stringer and railing **210** can contain an upper rail support railing cap **212A** which is attached to the upper rail support **212**. It can further contain a railing post attachment **220** attachable to each of the railing posts **214**.

It will be understood that each of the elements describe above, or two or more together, may also find useful application in other types of constructions differing from the type described above.

FIGS. 6–10 illustrate an alternative form of the stringer, riser and tread assembly in accord with the present invention. In this form a two piece stringer **310A** (lower) and **310B** (upper), as shown in FIGS. 6 & 7, is first attached to a deck or wall vertical surface by an attachment bracket **312**, as shown in FIG. 10, with the two pieces of the stringer attached to pivot holes **312A** in the bracket. Riser/tread supports **314** having pivot holes **316** spaced the same distances as the pivot holes in the attachment bracket are spaced along the risers and are fixed to the risers by suitable means at screw holes **318** to cause the riser/tread supports to be parallel to the attachment bracket and equally spaced along the risers. These vertical pivot riser/tread support **314** are unique because the supports pivot for adjustment only and are fixed in position after adjustment; the fixing of the riser/tread supports joins the two pieces of the stringer to form a one piece, permanently adjusted stringer which is structurally superior to normal stair construction; the positioning of the pivot points (opposite risers) allows the top of the stair to be attached the same distance down from the deck/floor level each time regardless of the riser height because all risers adjust equally including the first riser; the configuration of the riser/tread support allows risers **80** and treads **90** to slide against each other for adjustment; and when the risers are attached to the riser/tread supports and the treads, each riser then acts as a beam giving the stair much greater structural stability and allowing greater widths for a stair without additional supports. The riser/tread supports **314** can be constructed from metal, composites and other materials. It should be evident that the riser/tread supports **314** are now vertical if the surface of the deck where attachment was made was vertical when the attachment bracket was attached, and as illustrated in the two positions shown in FIG. 7, the riser/tread supports are now in position to be permanently attached to the stringers at securing holes **318** and to have risers **80** and treads **90** attached to the supports.

FIGS. 12–14 illustrate an alternative form of the stringer, riser and tread assembly formed using horizontal pivoted tread support brackets and including an alternative tread support with riser support elements. FIG. 13 shows alternative pivoting tread supports using a straight bracket **412** and FIG. 14 another support **414**, which is truncated in shape which can be used with or without a riser, but allowing greater fixing to the stringer. Riser **80** and treads **90** can still slide past

each other to form beams. There are three steps shown on the drawing which illustrates how this system would be installed with pivot points that are horizontal.

The feature of the riser/tread support in either the vertical or horizontal pivoted form is that it is a one piece apparatus which attaches to the two piece stringer using two pivot points which normally are vertical or horizontal but can be at any common angle. The riser/tread supports pivots to adjust for a required height to form the correct stair profile. The riser/tread support is then fixed in position (using nails, screws, bolts, glue, etc.) against the two piece stringer to form one solid, non-moving stringer which is capable of supporting both risers and treads or treads alone or risers alone (when being used for concrete formwork). The two piece stringer is then cut (at the dotted lines shown) to conform to the deck or wall at the top and the base at ground level at the bottom. The riser/tread support allows risers and treads to slide past each other so that the risers can be adjusted for height sliding up or down past the back of the tread. The back of the tread is pushed against the face of the riser to form an enclosed stair. The position of the risers and treads can vary infinitely in respect to each other depending on the stair adjustment.

FIGS. 15–17 illustrate a further alternative form for riser/tread supports **512** which are individually set on a two piece stringer **310A** and **310B** using removable setting blocks **514** and setting pins **516**. In this form the removable setting blocks **514** are used to space the riser/tread supports equally along the two piece stringer by being placed on a reference surface of a support and as their ends abut along the stringer. The stringer pieces are separated from each other by the removable setting pin **516** and the riser/tread supports **512** are attached at their pivot points **518A** and **518B** to the stringer **112** and to the stringer **114**. When the setting blocks **514** and the setting pins **516** are removed, the two parts of the stringer can be slid with respect to each other to adjust the riser/tread supports **512** in the desired vertical position and the riser/tread supports can then be secured to the stringers by screws, nails, or other fasteners at securing holes **520**. The riser/tread supports are then in position for the attachment of equally spaced treads and risers.

FIGS. 18–20 illustrate a stair section showing pivoting riser/tread supports using a single pivot point allowing the tread to be set level after stringer installation. Equally spaced support brackets **612** are pivoted at a single pivot **614** position of the stringer with those pivot positions being located the same distance below the deck/floor when the stringer is attached with the pivot position a desired distance below the level of the deck or floor to which the stair is to be attached. With a single pivot point for each of the equally spaced riser/tread supports, the supports can be attached to the second stringer by suitable means and the treads will always be equally spaced and will have equal rising distances. The single pivot point can be at any common point (shown as alternatives **614B**) along the riser/tread support brackets **612** and the brackets can be just a tread support or a tread and riser support. FIG. 20 illustrates an alternative form **612B** for the bracket in a truncated form.

FIGS. 21–25 illustrate another alternative form for riser/tread supports for use in the present invention. In this form the riser/tread supports **712** are individually set on a two piece stringer **112–114** using removable setting/spacing blocks **714**. This form of two piece stringer/riser/tread support assembly can be assembled with the stringers **112–114** and the riser/tread supports **712** in place by attachment means at the pivots **712A** and with the riser/tread supports spaced by the body **716** of setting/spacing blocks **714** mating and

cooperating extensions **718A** and **718B** with centering slots **720A** and **720B** in the riser/tred supports. When the assembly is to be used, **720A** and **720B** in the riser/tred supports. When the assembly is to be used, the setting/spacing blocks can then be removed from the riser/tred supports and the stringers can then slid with respect to each other to rotate the riser/tred supports about their pivot points. The stringer can then be attached to the face of the deck or wall where the stair is to be attached and the stringers can be cut (at possible cut lines shown) to face against the deck or wall. The riser/tred supports will then be equally spaced both vertically and horizontally, can be attached by suitable fastening means to the stringers, and are in position for installation of risers and treds.

FIGS. **26–33** illustrate another alternative form for a riser/tred support bracket **812**. This form may be formed from a metal or other suitable material blank **812A** with stamped holes, slots and side portions to form the bracket. The side portions **813** and **814** from the tread and riser support surfaces (respectively) with stamped holes **815** for attaching means for the treads and risers. Pivot holes **816** are used for connecting the bracket to the stringers and holes **817** are for fixing the bracket in place when a stringer assembly is completed. The bracket **812** is provided with stamped alignment guide holes at **819** and a guide slot at **820**.

FIGS. **29–31** illustrate a setting and spacing bar **822**. The setting and spacing bar may be formed of metal or other suitable material and includes a central body portion **823** with folded ears **824** at each side and with a guide tab **825** formed at each end of the body portion.

The setting and spacing bar **822** is adapted to cooperate with and space two brackets **812** by aligning the guide tab **825** with the guide hole **819** at one bracket and with guide slot **820** in the next bracket and serves to establish the spacing between brackets. The folded ears **824** separate two stringers and thus to allow for the space for relative movement between stringers.

With at least a pair of brackets **812** spaced by setting and spacing bars **822** and an upper and lower stringer the brackets may be attached by suitable means to the stringers at the pivot holes **816** to provide aligned and spaced riser/tred brackets for a stair assembly as will be described with reference to FIGS. **34–38**.

FIGS. **30–33** illustrate alternative forms for riser/tred brackets similar to that shown in FIGS. **26–29**. FIG. **30** illustrates a bracket **812** with a setting and spacing bar **822** integrally formed with the bracket. The bar **822** has a length designed to space adjacent brackets and a near central folded ear portion **824** for spacing stringers. The bar **822** would be detachable after it has functioned in setting and spacing. FIG. **31** illustrates another alternative of an integrally formed bracket **812** with a removable spacing bar **822** and a central setting body **824**. FIG. **32** is another alternative bracket similar to FIG. **31** with a removable spacing bar **822** and a central plug **826** for spacing the stringers. FIG. **33** illustrates alternative forms for the end of a spacing bar **822** to adapt the bracket to different spacings of brackets along a stringer assembly. The spacing bar may include holes or pins at **822A** or notches at **822B**. Spacing bars of the type shown here can be used with the brackets **116** shown in FIG. **5** by cooperating with the spacer slots **115** in positioning brackets **116** before stringers **112** and **114** are moved relative to each other in setting the brackets **116** for receiving treads and/or risers.

FIGS. **34–36** illustrate the use of the brackets with stringers in the formation of a stair assembly. FIGS. **34A** and **34B**

illustrate the opposite sides of a stair stringer assembly, each side having an upper **112** and lower **114** stringer with a plurality of brackets **812** of the type illustrated in FIGS. **26–29** (or of the types shown in FIGS. **1–25**) and employing setting and spacing bars **822** to position the brackets along the stringers. The two stringer assemblies mirror each other to be left and right sides of a stairway. When assembled, spaced and guided, the brackets are attached to the stringers by suitable means through pivot holes **316**. FIGS. **35A** and **35B** illustrate the moved portion of the stringers **812–814** and the rotation of the brackets **812** to the deaired position for attachment to a deck or wall and for tread and riser attachment after cutting the stringers for attachment to the deck or wall. At this stage in the formation of the stringer assembly the brackets **812** can be permanently attached to the stringers at the provided attachment holes.

FIGS. **36A** and **36B** illustrate the completed stair using the brackets and movable stringers of the present invention. It should be noted that the forward holes **815** along the tread side portions **813** of the bracket of FIG. **26** permit the location for predrilling guide holes into a tread from below. By knocking the tread against the bracket, the raised holes will mark the underside of the tread. Predrilling guide holes will permit ease of assembly of the tread from below before a riser is added to the face of the stair.

FIGS. **37** and **38A** illustrate the use of the principle of the present invention for the positioning of formwork for poured concrete stairs. The use of two part parallel stringers with pivoted riser/formwork supports permits the setting of equally spaced horizontal riser forms and equally spaced vertical spaces between poured stairs. The two piece stringer is first set at the desired angle and the separated stringer parts are fixed with respect to the top and bottom of the desired stair. Equally spaced riser/formwork supports are positioned along the risers by attachment at pivot points with the support elements having adjustment slots (FIG. **37**) or by the use of locking holders (FIG. **38B**). Riser formwork elements are attached to the free end of each of the supports. Concrete aggregate can then be poured behind each of the riser formworks to the desired level for the stairs and allowed to set. It should be evident that the face of the riser formwork elements can be adjusted to a desired angle other than vertical by adjusting the relative positions of the two stringer elements. The riser height adjustment can be achieved by setting the first and last support and their riser formworks in position and then raising or lowering intermediate supported riser formworks to a string line drawn from the first to the last support. Equally spaced horizontal supports will then result in equally spaced vertical riser formworks.

While certain preferred embodiments of the invention have been specifically disclosed, it should be understood that the invention is not limited thereto as many variations will be readily apparent to those skilled in the art and the invention is to be given its broadest possible interpretation within the terms of the following claims.

We claim:

1. A riser/tread support bracket and aligning/spacing means kit for use with duplicate kits in an adjustable stair assembly for at least one side of a stairway, said stair assembly having a pair of parallel stringers at said at least one side, a plurality of said support brackets adjacent to each other along said parallel stringers, and said aligning/spacing means of said kit being adapted for spacing and aligning said support bracket of said kit with respect to adjacent support brackets from said duplicate kits along said parallel stringers and for spacing said parallel stringers:

said support bracket of said kit comprising,

- a) a support bracket having a tread support surface and at least a reference surface having engagement means, and means for accomodating fastening means,
 - b) said means for accomodating fastening means comprising a pair of holes in said support bracket, one of said pair of holes being adapted and aligned for pivotally attaching said support bracket to one of said spaced parallel stringers, the other of said pair of holes being adapted and aligned for pivotally attaching said support bracket to the other of said parallel stringers,
- said aligning/spacing means of said kit comprising,
- c) an elongated member having a first element at each end thereof, said first element at one end of said elongated member cooperating with said engagement means of said support bracket and establishing a non-rotatively fixed positioning of said support bracket with said aligning/spacing means for distance and direction alignment and spacing of said support bracket with respect to an adjacent duplicate support bracket of a duplicate kit along said parallel stringers, and
 - d) a second element integrally connected to said elongated member and extending laterally from a side surface of said elongated member, said second element extending beyond a side of said support bracket for insertion between said parallel stringers to establish a spacing and lateral positioning of said parallel stringers with respect to said support bracket and aligning/spacing means,
- whereby said support bracket of said kit is adapted to be pivotally attached to said spaced parallel stringers, is adapted to be spaced from another support bracket of a duplicate kit by said first element of said aligning/

- spacing means, and adapted to be pivotally movable with parallel surfaces of said spaced parallel stringers.
- 2. The aligning/spacing means or the kit of claim 1 wherein said first element or said aligning/spacing means is adjustable to provide selectable spacing between said support bracket and an adjacent support bracket of a duplicate kit.
 - 3. The riser/tread support bracket of the kit of claim 1 wherein:
 - a) said engagement means comprises a pair of alignment means being formed on opposite spaced end sides of said support bracket,
 - b) said pair of engagement means being in alignment across said support bracket parallel to said tread support surface.
 - 4. The riser/tread support bracket of the kit of claim 3 wherein:
 - a) one of said pair of engagement means is a slot formed in said one of said spaced end sides,
 - b) and the other of said pair of engagement means is a notch formed in an opposite one of said spaced end sides.
 - 5. The aligning/spacing means of the kit of claim 1 wherein:
 - a) said aligning/spacing means is a bar,
 - b) said bar having said first element at each end of said bar for establishing said non-rotatively fixed positioning of said bar with respect to said reference surface of a support bracket,
 - c) said second element is a projection from a side surface of said bar integral with said first element for insertion between said parallel stringers to establish lateral spacing of said parallel stringers.

* * * * *

UNITED STATES PATENT AND TRADEMARK OFFICE
CERTIFICATE OF CORRECTION

PATENT NO. : 6,354,403 B1
APPLICATION NO. : 09/315809
DATED : March 12, 2002
INVENTOR(S) : Richard Truckner and Paul Truckner

Page 1 of 1

It is certified that error appears in the above-identified patent and that said Letters Patent is hereby corrected as shown below:

IN THE ABSTRACT

LINE 3, "tred" should be --tread--

IN THE SPECIFICATION

COL. 5, lines 6, 9, 10, 11, 12, "banister" should be --ballister--

IN THE CLAIMS

COL. 10, lines 4 and 5, "or" should be --of--

Signed and Sealed this

Thirtieth Day of January, 2007

A handwritten signature in black ink on a light gray dotted background. The signature reads "Jon W. Dudas" in a cursive style.

JON W. DUDAS

Director of the United States Patent and Trademark Office